

Editor manual



ProcessMap

Version 3.1

Copyright

This manual is protected by international copyright law. No changes of content or reproduction of parts of this publication are allowed without permission from the publisher.



Editor Manual for ProcessMap version 3.1

Created March 19, 2009

Last edited January 25, 2012

© Meridium Kalmar

Content

1.	Introduction	3
1.1.	Prerequisites	3
1.2.	Manual conventions	3
1.3.	Relation to other manuals	3
2.	Start	4
2.1.	Edit mode	4
3.	Creating a process map	5
3.1.	Editor tabs	5
4.	ProcessMap graphical editor	6
4.1.	Main interface	6
4.1.1.	Start button	7
4.1.2.	Quick access toolbar	7
4.1.3.	Zoom	9
4.1.4.	Command Ribbon	9
4.1.5.	Rulers	12
4.1.6.	Grid	12
4.1.7.	Quick menus	13
4.2.	Drawing a process	15
4.2.1.	Symbol properties	15
4.2.2.	Manipulating objects	15
4.2.3.	Selecting a symbol	16
4.2.4.	Selecting multiple symbols	16
4.2.5.	Moving a symbol	17
4.2.6.	Rotating a symbol	17
4.2.7.	Resizing a symbol	19
4.2.8.	Copy symbol format	20
4.2.9.	Changing symbol color	20
4.2.10.	Adding text	21
4.2.11.	Removing text	21
4.2.12.	Changing font	22
4.2.13.	Text alignment	22
4.3.	Using lines	24
4.3.1.	Line types	24
4.3.2.	Changing line properties	26
4.3.3.	Moving lines	27
4.3.4.	Line text	27
4.3.5.	Connecting lines	28
4.3.6.	Interconnecting lines	29
4.3.7.	Rerouting lines	29
4.3.8.	Text objects	29
4.4.	Editing a ProcessMap	30
4.5.	Arranging symbols	30

4.5.1.	Grouping objects	31
4.6.	Aligning symbols	32
4.7.	Format shape settings	34
4.7.1.	Line settings	34
4.7.2.	Symbol settings	36
4.7.3.	Text	37
4.7.4.	Advanced settings	38
4.8.	Custom symbols	43
4.9.	Adding content	43
4.9.1.	Web page link	44
4.9.2.	File link	45
4.9.3.	E-mail address	45
4.9.4.	EPiServer link	46

I. Introduction

Welcome!

ProcessMap is a plug-in for EPiServer. It is used to visualize processes and to connect the various steps of a process to i.e. documents, web pages or other sources of information. The ProcessMap plug-in is fully integrated into the EPiServer environment and can utilize standard EPI functions like search and version control. Process maps are easily created with the built in, and easy to use, drawing program.

This manual describes how the editor, a person whose day to day task is to create content in the EPiServer environment, can use ProcessMap in the most efficient way.

I.1. Prerequisites

The editor will need a configured client installation. How to install and set up the client environment is covered in the manual “ProcessMap: Installation & administration manual”.

I.2. Manual conventions

Certain typographic conventions are used in this manual.

Running text is presented in the times font. Notes, tips and warnings are presented in bold.

Note! A note. Highlights important information.

Tips! A tip. Contains an advice or an easier way to do something.

Warning! A warning! Highlights that problem might occur and how to avoid it.

I.3. Relation to other manuals

This manual is part of a series of 2 manuals. This manual is sufficient reading for the editor. The other manual, ProcessMap: Installation & administration manual, is aimed towards administration and development. Recommend reading is also the standard documentation for EPiServer. The documentation for ProcessMap can also be found online at <http://www.meridium.se>.

2. Start

To be able to use ProcessMap an account in EPiServer with editing permissions is needed. Basic knowledge of page creation and editing pages in EPiServer is also needed. More information on page creation and editing can be found in the EPiServer Editor Manual.

2.1. Edit mode

Edit Mode is a requirement for page creation or editing. Log into edit mode by either using the server address followed by /edit, i.e. www.yourorganisation.com/something/edit, or by pressing the right mouse button followed by selecting **Edit Mode** on the pop-up menu.

Note! The /edit address is common for edit mode, but an extra search path is normally added for security reasons (i.e. www.yourorganisation.com /something/edit). Refer to site-specific documentation or your ImageVault administrator for information on how to enter the edit mode on your server.

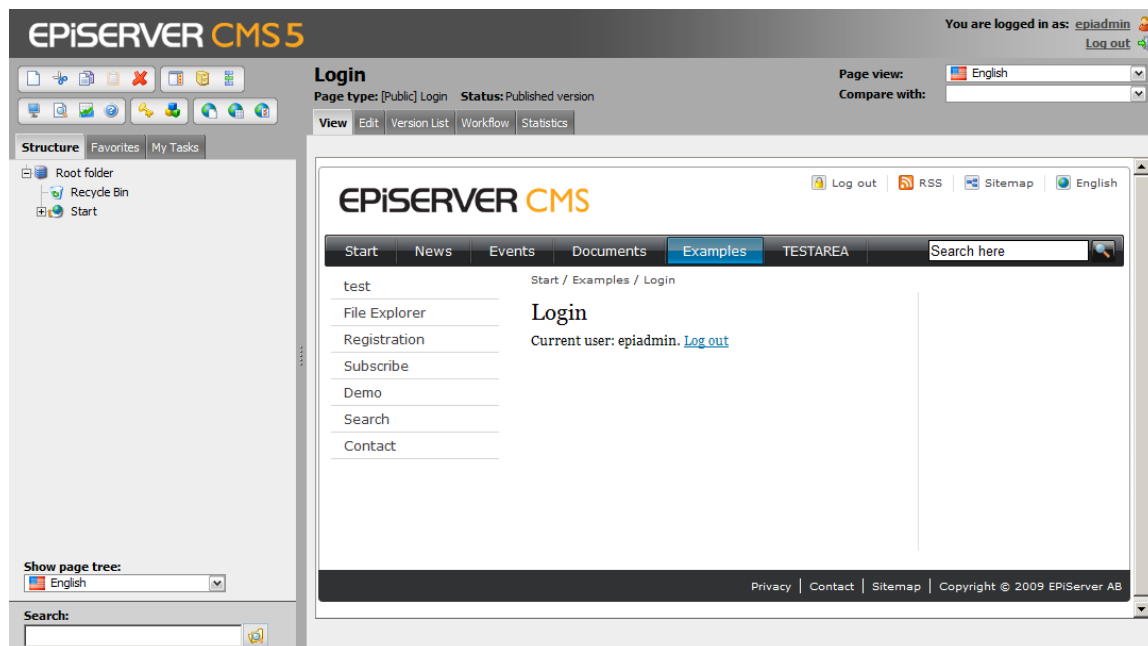

EPiServer in edit mode

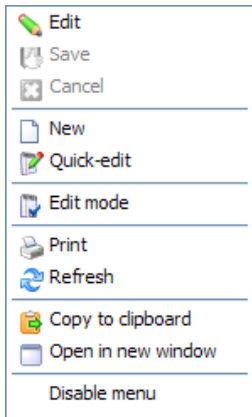

Pop up menu

3. Creating a process map

Navigate in the EPiServer structure and select where the page should be created. The selected branch will be highlighted in bold. Choose either **Create New** in the upper toolbar or press the right mouse button on the branch and select **Create New** from the pop up. If an existing page needs editing, choose the menu option **Edit** instead.

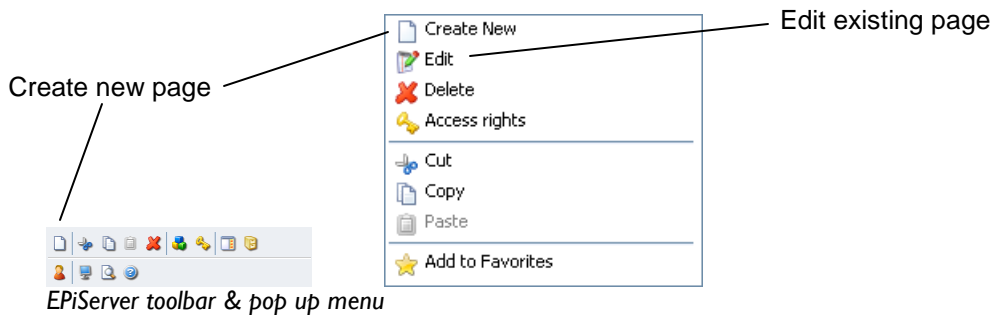

EPiServer toolbar & pop up menu

ProcessMap is integrated into EPiServer and adds a new page type called “ProcessMap default page”. Depending on how the web server is configured there can be several different types of templates available. Locate the “ProcessMap default page” template and select **Create**.

Note! Please refer to EPiServer editor manual for a more in-depth description of the various EPiServer specific properties.

3.1. Editor tabs

The newly created ProcessMap will have a number of tabs on the edit page. Since EPiServer offers an extremely high degree of configurability and template appearance will vary. Please refer to your administrator or site-specific documentation on how your particular template is configured.

Tips! All fields on the tabs have popup help texts. Position the mouse cursor on the field name to display the help text.

4. ProcessMap graphical editor

The ProcessMap graphical editor is an easy to use tool for drawing process maps. Pressing the **Edit processmap** button located on one of the edit tabs starts the editor. The program will start in a separate window. The button **Delete** will delete the current Processmap.

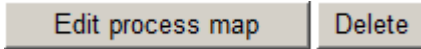

ProcessMap buttons

Note! The ProcessMap start button tab location will vary depending on configuration of the template.

4.1. Main interface

The interface is composed of the command ribbon and the main drawing space.

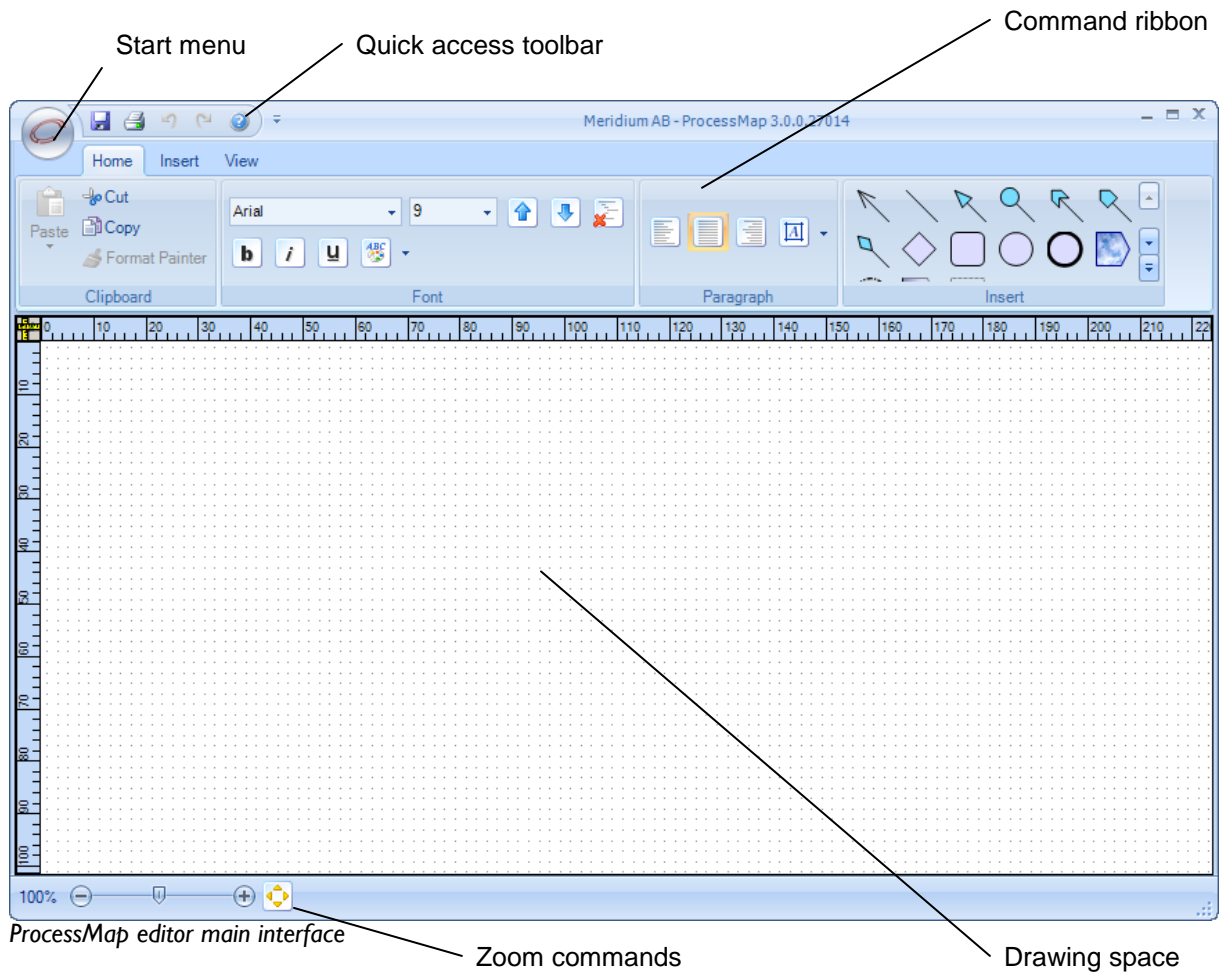

4.1.1. Start button

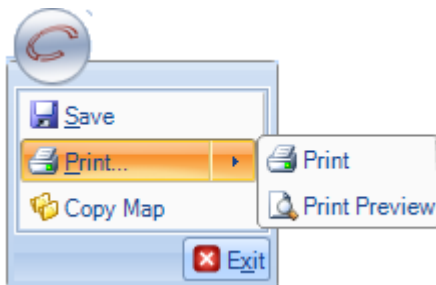

ProcessMap start button

The ProcessMap start button holds the most common commands for printing and saving the map. It is also possible to copy an existing map by using the command **Copy Map**. The **Copy Map** command will bring up a dialog showing a list of the maps available for copying.

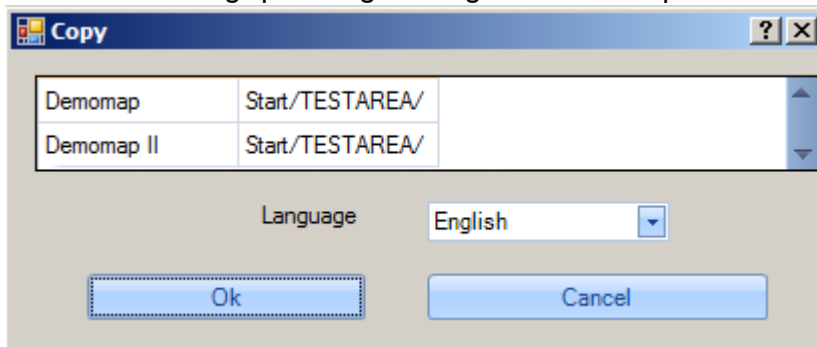

Copy map dialog

Note! The list of available maps may be restricted by the current user access rights.

The command **Exit** will close the ProcessMap editor. The user will be presented with a choice to save the current ProcessMap before the editor is closed, in case the map has been changed.

4.1.2. Quick access toolbar

The quick access toolbar is a quick and easy way to access the most common commands. The toolbar is configurable.

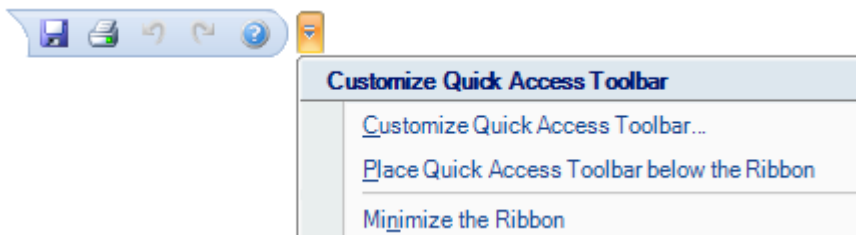

Quick Access toolbar

The default commands are Save, Print, Undo, Redo and Help.

Save

Saves the current ProcessMap.

Print

Prints the current ProcessMap.

Undo

Undo the most current command.

Redo

This command will cancel the undo command and return the drawing space to its previous state.

Help

Displays context sensitive help.

The toolbar editor is started by pressing the button to the right of the toolbar and selecting **Customize Quick Access Toolbar**.

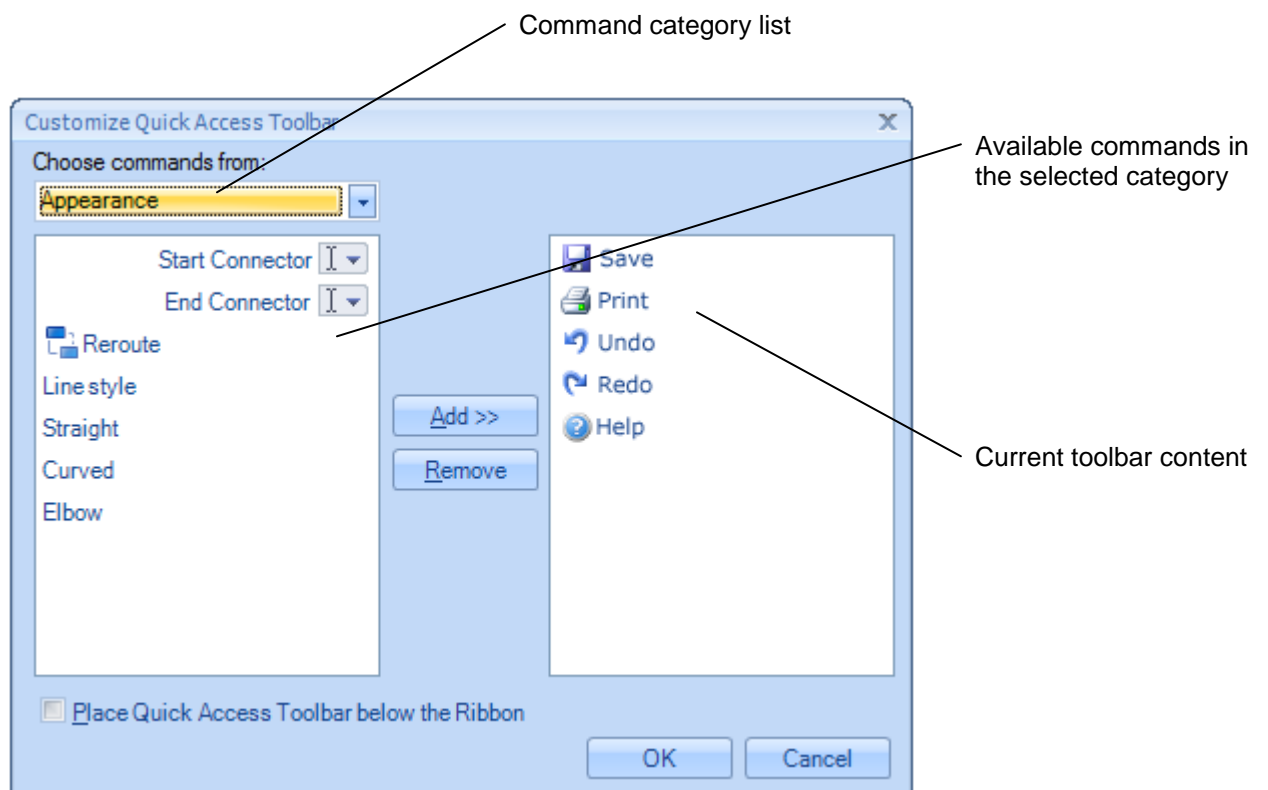

Quick Access Toolbar Editor

The available commands are divided into different categories. Switch command category by using the drop down list in the top left corner. Move a command to the toolbar by selecting the command in the left window followed by pressing **Add**. To remove a command from the toolbar, select the command in the right window and press **Remove**.

Used for setting different fonts and styles in symbols or text objects.

3. Paragraph

Used for aligning text, both horizontally and vertically.

4. Insert

Used for selecting which line or symbol to use.

Insert tab

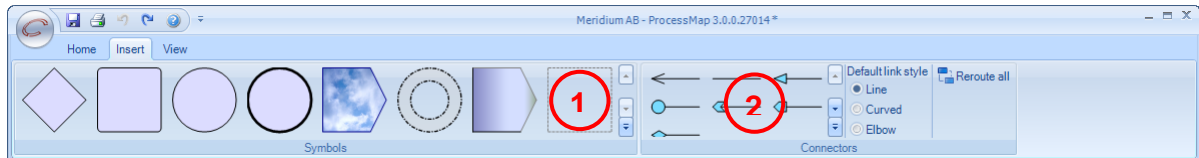

1. Symbol library

Used for selecting which symbol to use.

2. Line Library

Used for selecting which line to use.

View tab

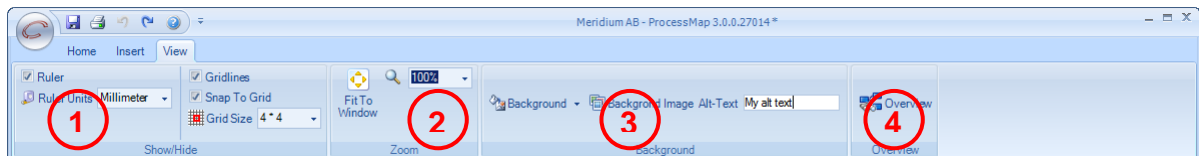

1. Ruler/Gridlines

Used for settings of rulers, drawing space grid and spacing of the grid.

2. Zoom

Zoom settings for the drawing space. Also available in the lower left corner of the application.

3. Background

Used for settings for background color, background image and alt text for the drawing space.

4. Overview

Used for an easy to use overview of the current process map.

Format tab

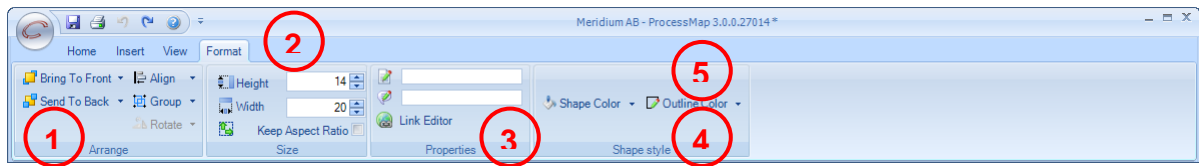

5. **Arrange symbols**
Used for arranging symbols, both stack order, grouping and alignment.
6. **Size settings**
Used for size settings for symbols.
7. **Properties**
Used for adding text, alt text and links.
8. **Shape style**
Used for setting the shape and outline color. This setting is only visible if a symbol is selected.
9. **Appearance**
Used for setting different line properties like start shape. This setting is only visible if a line is selected.

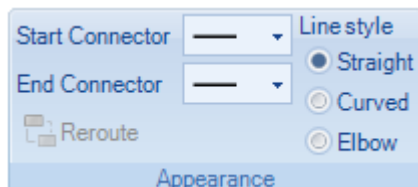

Line appearance

Certain parts of the tabs will be hidden if the ProcessMap windows size is decreased. The settings will then be presented as a button. Press the button to show the setting.

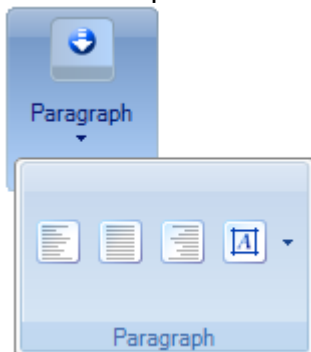

Minimized setting

Note! The format tab is only visible if an object is selected.

4.1.5. Rulers

Rulers surround the drawing space. Ruler settings like dimension and visibility are set using the View tab. The setting **Ruler** will show or hide the rulers. The setting **Ruler Units** will swap the units between millimeters and pixels.

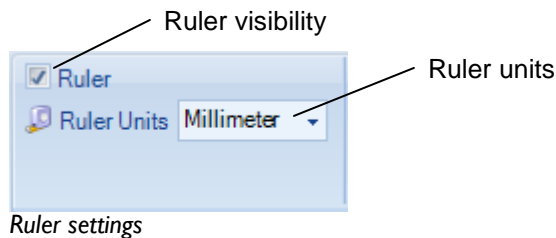

4.1.6. Grid

Depending on the settings the drawing space can be equipped with a grid. A grid will force every object that is created, moved or manipulated in any way to snap to the closest grid point. Each grid will have a preset spacing between the grid points. There are three types of grid available:

- Dots The grid points are presented as small points on the drawing space
- Hidden The grid points are invisible, but still active
- Lines The grid points are presented as lines on the drawing space

The grid settings can be accessed by the command ribbon View tab.

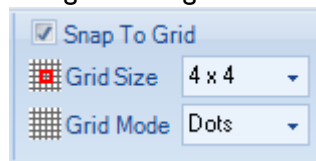

Gridlines settings

Enabling the option **Gridlines** will activate the grid. The option **Snap To Grid** will enable or disable the grid. The option **Grid Size** sets the spacing of the grid. This value is presented in pixels.

Note! The grid might be visible even if it is not active due to the fact that the commands snap to grid and gridlines are separated.

4.1.7. Quick menus

The quick menus are invoked by pressing and holding the right mouse button. The commands in the quick menu can also be found in the command ribbon, but the workflow can become more streamlined when using the menus, since access to the commands are quicker.

Tips! Maximize the drawing space by selecting the quick access toolbar option *Minimize the Ribbon* command.

Symbol/lines quick menu

This menu is invoked by pressing and holding the right mouse button with a symbol or line selected.

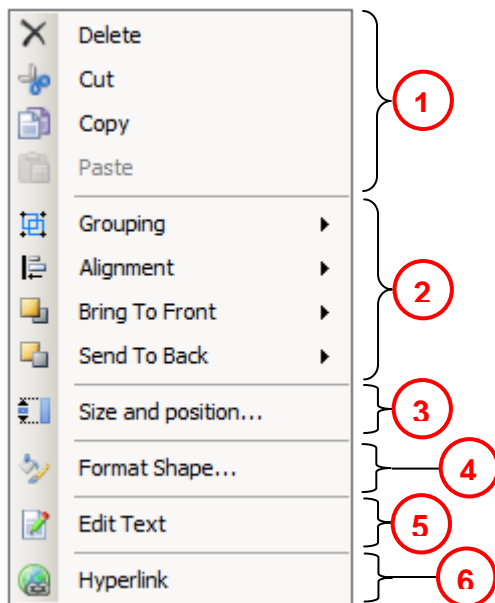

Quick menu

1. Edit section
Used for standard cut, copy, paste operations.
2. Align/group section
Used for grouping and aligning symbols.
3. Size and position settings
Used for size, angle and position settings.
4. Format shape
Used for object properties like color, line type, dash type etc.
5. Edit text
Used for editing symbol text.
6. Hyperlink
Used for adding links to symbols with the link editor.

The menu changes appearance slightly when a line is selected.

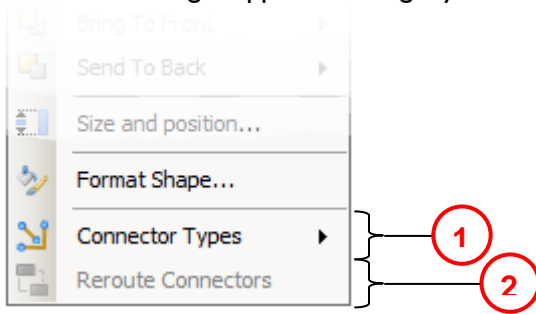

1. Connector types
Used for changing the line type.
2. Reroute connectors
Used to reroute the lines. This option is only available for the elbow line type.

Drawing space quick menu

This menu is invoked by pressing and holding the right mouse button with nothing selected.

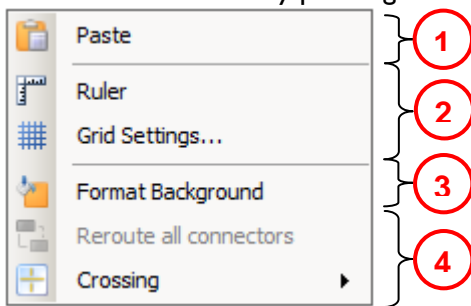

Drawing space quick menu

1. Edit section
Paste clipboard contents with the Paste command.
2. Ruler settings
Set ruler properties like visibility and grid spacing with this command. Refer to section 4.1.5 for more info.
3. Background settings
Set background properties like color, tint or picture background with this command.
4. Route/Crossing section
Choose line intersection options or automatically reroute all lines with these two commands.

4.2. Drawing a process

Start by selecting a symbol from the symbols or lines library found on either the home or insert tab in the command ribbon. Press and hold the left mouse button. Drag the mouse to set the symbol size. Line length is set by pressing the mouse button at the insert point and then dragging the mouse pointer to the location for the end point. All symbols have a default size and color. Lines have a predefined line color, startpoint and endpoint connectors.

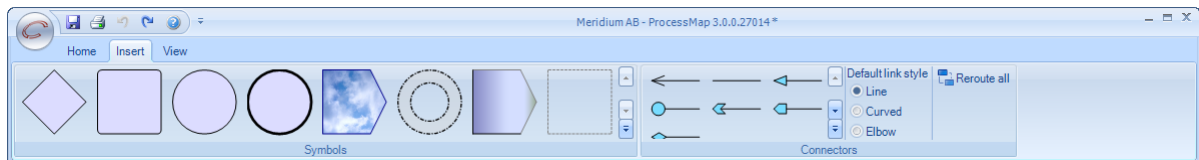

Insert tab symbol and line library

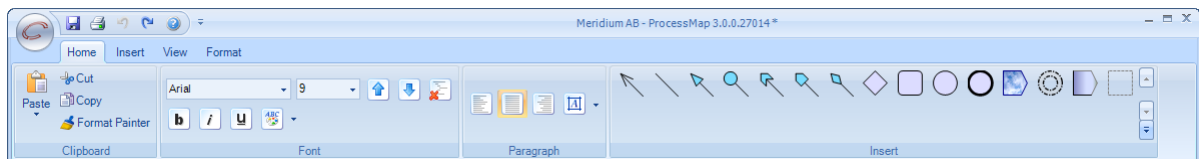

Home tab symbol and line library

4.2.1. Symbol properties

A symbol is made up of several properties. Refer to the picture below to identify the different properties.

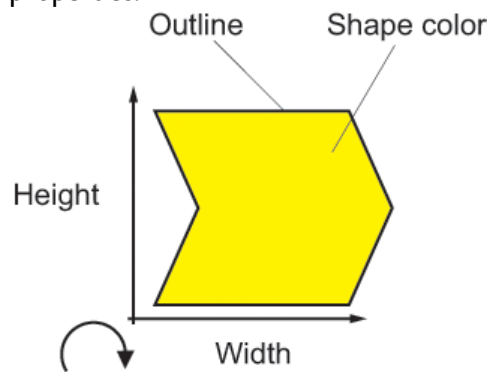

Angle
Symbol properties

Note! Angle is not applicable for all symbol types.

4.2.2. Manipulating objects

In order to manipulate symbols, i.e. moving, grouping, the objects must be selected. ProcessMap 3, as opposed to previous versions, does not require any special mode for object selection.

4.2.3. Selecting a symbol

Before it is possible to modify an object it needs to be selected. To select an object left click with the mouse pointer positioned over the object. It is also possible to use the marquee to select the object.

The marquee is the temporary border that will become visible when the left mouse button is pressed and the mouse pointer is dragged along the drawing space. The marquee does not need to fully enclose an object to make it selected.

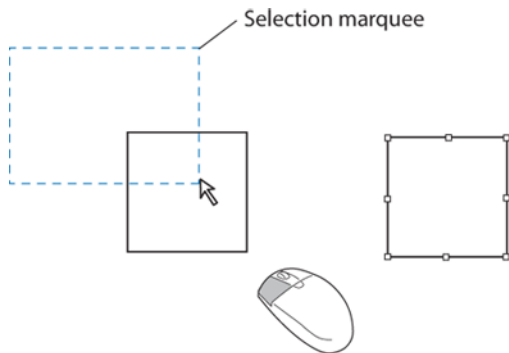

Selection using a marquee

4.2.4. Selecting multiple symbols

Multiple objects can be selected by either drawing a selection marquee on the drawing space, or by holding the ctrl button and left clicking each object that is going to be part of the selection.

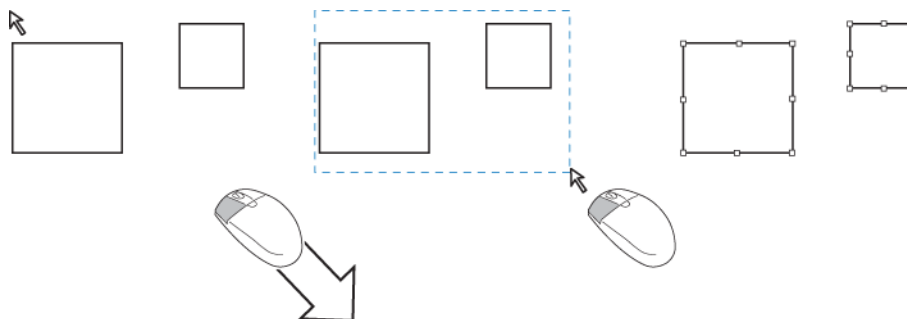

Multiple selections

Note! The marquee does not need to fully enclose the selected shapes.

4.2.5. Moving a symbol

Left click on the symbol to select it. Release the button and position the mouse pointer at the center of the symbol. The mouse pointer will change from an arrow pointer to a cross. Press and hold the left mouse button. Drag the symbol to a new location.

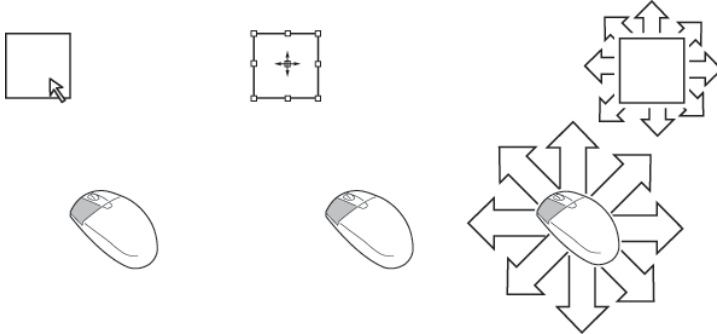

Moving a symbol

4.2.6. Rotating a symbol

Some symbols are equipped with a special rotate handle. Press the left mouse button, with the pointer positioned over the handle, and move the mouse to the right for clockwise rotation and to the left for counter-clockwise rotation.

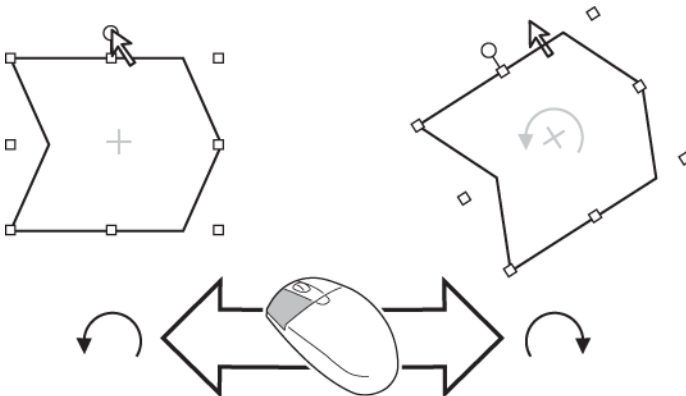

Symbol rotation

A symbol can also be rotated by either using the command ribbon format tab or the quick menu. Select the symbol and select the option **Size and position...** Positive values will rotate the symbol clockwise and negative values will rotate the symbol counter clockwise.

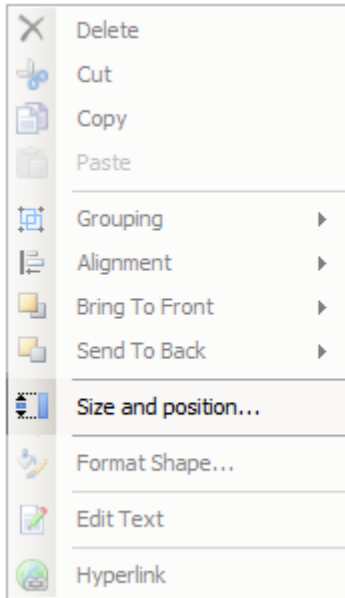

Rotate symbol quick menu settings

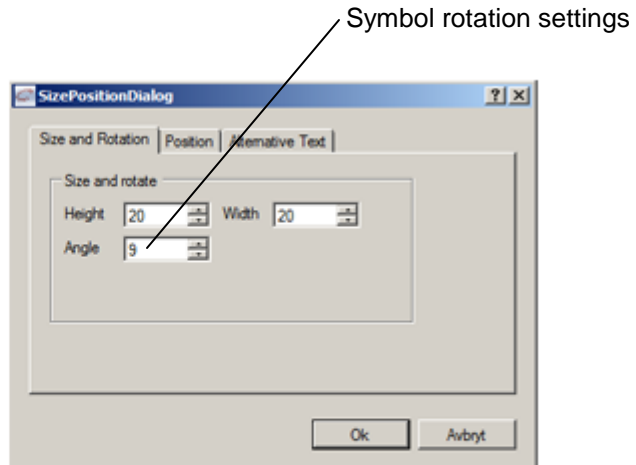

4.2.7. Resizing a symbol

Select the symbol. Resize by left clicking on either of the white squares (resizing handles) that surround the symbol.

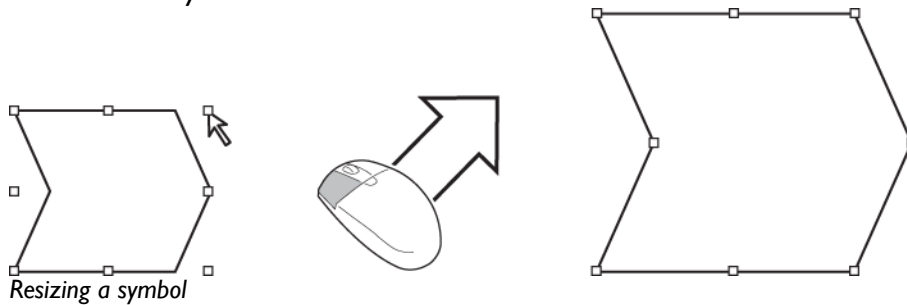

An alternate way of resizing is to use the format tab. Change the fields **Width** and **Height** to a suitable value. The option **Keep Aspect Ratio** will force height and width to be scaled the same amount regardless of how the symbol is resized.

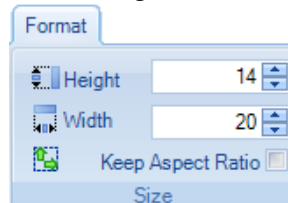

Format tab size settings

Alternative ways are the quick menu. Select the option **Size and position...**

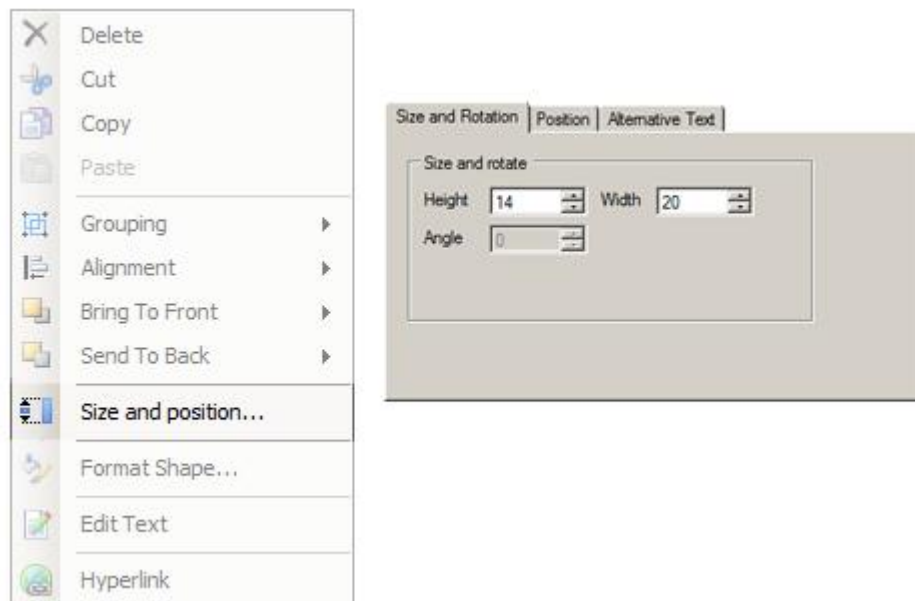

Quick menu size settings

Note! Only the resizing handles that are located in the corners will allow bi-directional resizing.

Note! All symbols have a predefined minimum size, which cannot be overridden.

4.2.8. Copy symbol format

It is possible to copy all symbol properties to another symbol by using the format painter. This will transfer all properties except the shape to the new symbol.



Format painter

Start by selecting the symbol with the properties that is going to be transferred. Press the format painter. The mouse pointer will now be shaped like a brush. Select the target symbol. The target symbol has now inherited all properties of the source symbol.

Note! Double click on the Format Painter symbol to keep it active. This way it is possible to transfer properties to several objects. Click once again on the symbol to deactivate it.

4.2.9. Changing symbol color

Each symbol has a default color for the symbol background color and the frame color. The colors can be easily changed in the format tab. Select the symbol and change the color of the background in the field **Shape Color**. The frame color is set in the field **Outline Color**.

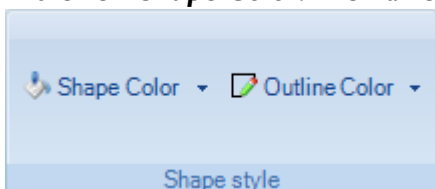

Shape and outline color

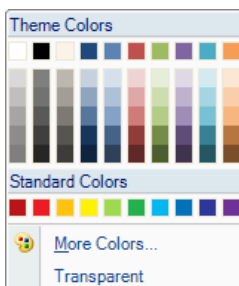

Color palette

Both the frame and the background color are changed by using the color palette. Activate the palette by pressing either Shape Color or Outline Color. Pick a color from the palette.

Note! The administrator sets the composition of the color palette (number of colors and tint).

4.2.10. Adding text

Text is added in the text field found on the format tab. The text will appear inside the symbol.

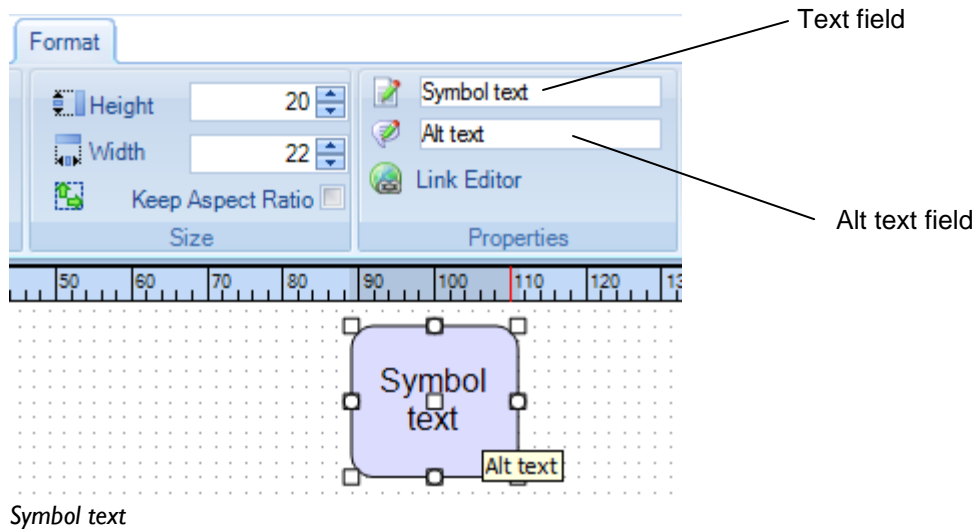

Symbol text

The default placement for the text is center. The text alignment, font and font size can easily be changed by using the settings in the Home tab. See section 4.2.13 for text alignment settings.

It is possible to add text to several symbols at once. Select the symbols either by using a selection marquee or by pressing the ctrl key and selecting the symbols by left clicking.

Tips! It is also possible to add text by double clicking on the symbol.

4.2.11. Removing text

Double click on the symbol and remove the text by using standard text commands like delete or cut, or select the symbol and press the text removal button  found in the Home tab.

4.2.12. Changing font

Each symbol has a default font used for text presented within the symbol. The font type can be easily changed in the Home tab. Activate the symbol by left clicking. Change the font by selecting a new font family in the drop down list.

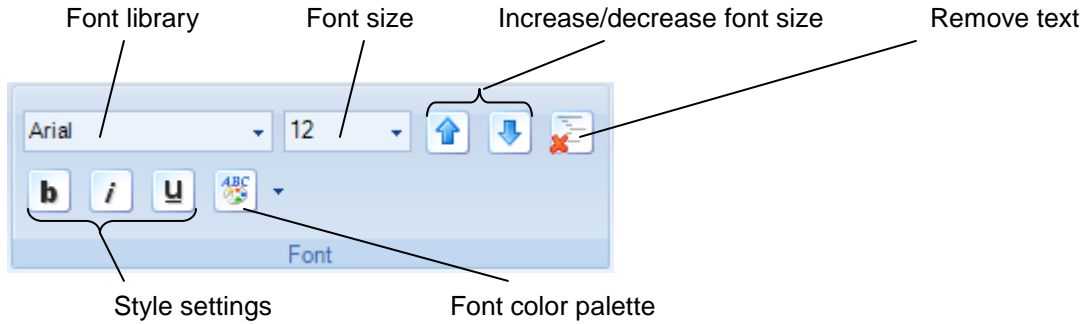

Home tab font settings

Change the font color by using the font color palette. Activate the palette by pressing the palette button. Pick a color from the palette.

It is also possible to change the fonts and styles by double clicking the symbol and, once the symbol text input mode is active, press the right mouse button. This will invoke the font settings menu.

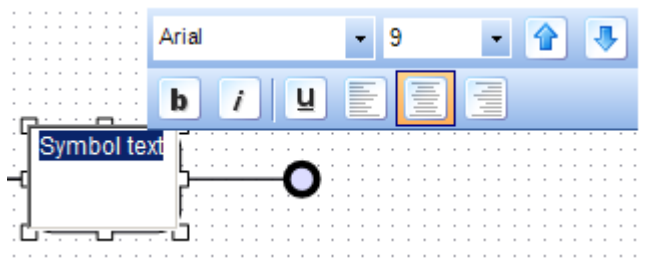

Font settings menu

Note! The administrator sets the composition of the color palette (number of colors and tint).

4.2.13. Text alignment

Text alignment can be set to left, center and right. Select the symbol and switch to the Home tab. Use the paragraph settings to change horizontal and vertical alignment.

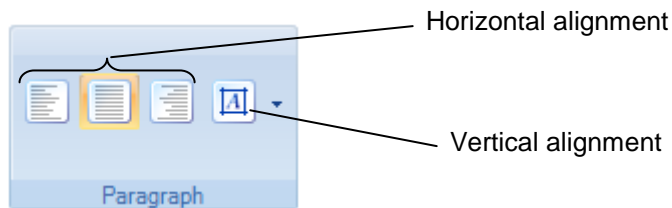

Paragraph settings

An alternative way is to select the symbol and right click to invoke the quick menu. Select the option **Format Shape...** .

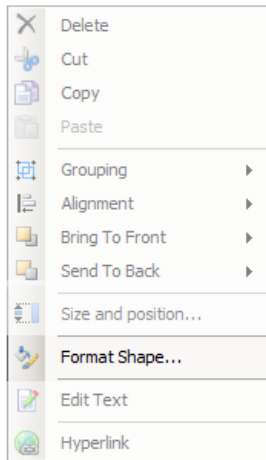

Quick menu

Select the option Text in the rightmost window pane. Change the text placement by changing the vertical or horizontal text alignment.

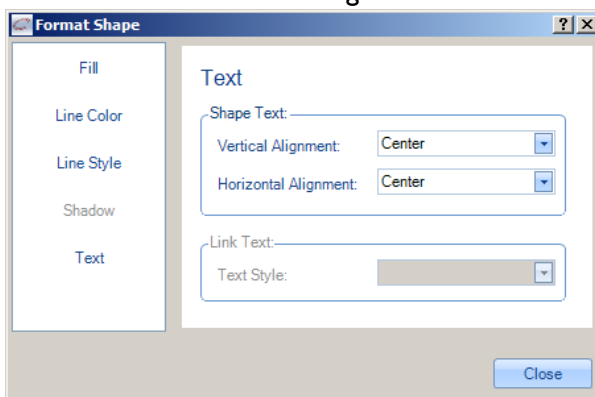

Format shape text settings

4.3. Using lines

Different types of lines are used to interconnect the symbols. The lines are stored in the line library. All line properties can be changed after the line creation is complete. Lines can only be connected to the symbols at specific line connection points. Most symbols have several predefined connection points that become visible when the mouse pointer is positioned over the symbol.

Connection point

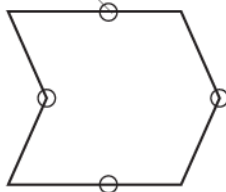

Line connection points

Note! Not all symbols are equipped with connection points.

Note! The current line type will stay active until a new line type is selected.

Select a line in the library. Position the mouse pointer in the vicinity of one of the connection symbols. The mouse pointer will change to a pointing hand when the line is ready to connect to the connection point. Press the left mouse button and drag the pointer to the connection point on the other symbol. The line will automatically snap to the closest connection point, both on the first and second symbol.

4.3.1. Line types

There are three different line types available: polylines, bezier line and perpendicular line.

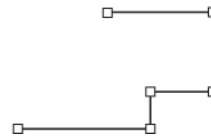

Line types

Line

All lines are per default polylines. A polyline is a straight line between two points with the possibility to add more points. Position the mouse pointer on the line; press the left mouse button and drag to add new line points. Remove points by dragging and releasing the points on another point.

Curved

A bezier line is a curve. The curve is equipped with handles. The handles act as levers and will adjust the shape of the curve. A bezier curve consists of a fixed number of points, which cannot be changed.

Elbow

A perpendicular line can only be horizontal or vertical. Each segment of the line is perpendicular to the segments it is connected to. Position the mouse pointer on the line; press the left mouse button and drag to add new line segments.

The current line type is highlighted in the quick menu. Select the line and invoke the quick menu. The line type is highlighted in the menu selection Connector Types. This sub menu can also be used to change the line type.

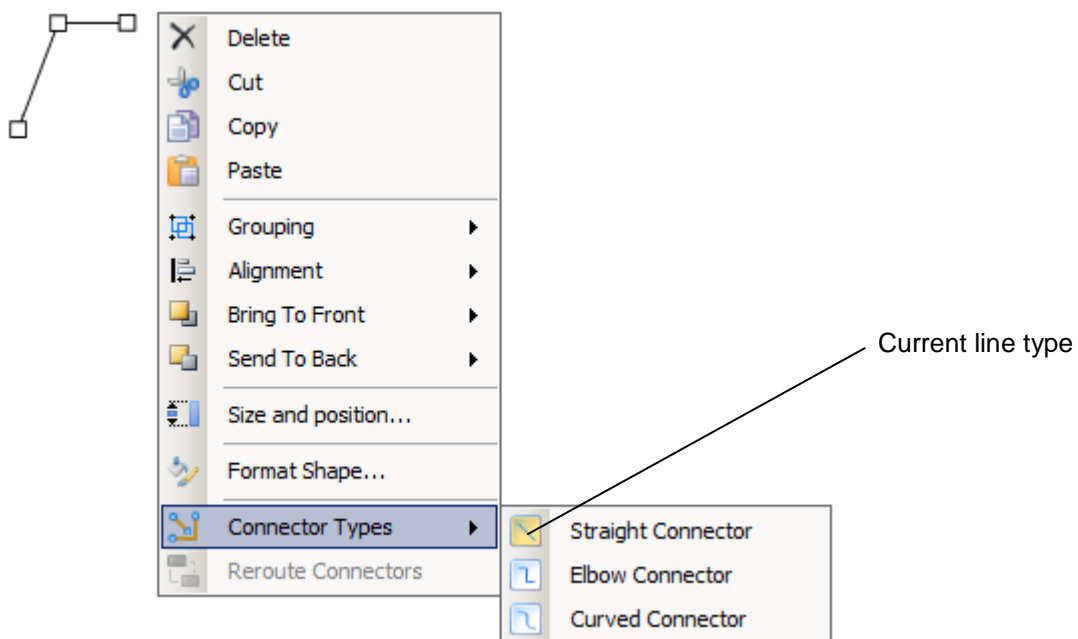

Line type

Tips! A curved line will inherit any number of points from the previous line type. Create a line and add several points. Convert the line to a curved line and you will have more points to edit.

4.3.2. Changing line properties

All lines have properties. The line properties can be changed in either the format tab or the quick menu.

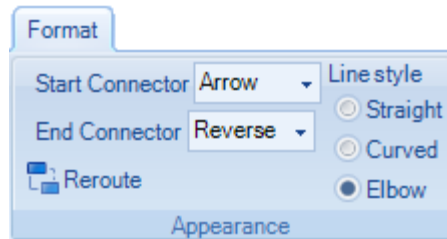

Format tab line settings

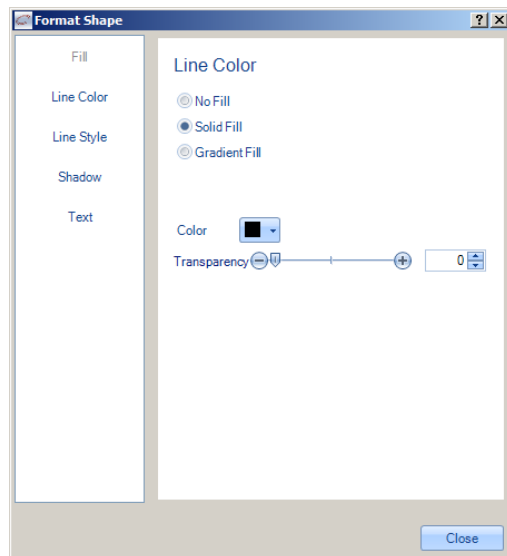

Format shape settings

Examples of properties that can be changed are:

Size

The width of the line in pixels. The default value is 1.

Color

The line color.

Start connector

The symbol used at the start point of the line.

End connector

The symbol used at the end point of the line.

Each properties field can be changed. All changes will be reflected immediately on the drawing space.

The settings are described in more detail in the format shape section 4.7.1.

4.3.3. Moving lines

To move a line select the line and then use the up, down, left or right keys on your keyboard. Using the mouse will add points to the line, or only move the endpoint or start point of the line.

4.3.4. Line text

All lines can be equipped with text. Text is added in the text field. Select the line and add the text in the symbol text field found in the format tab.

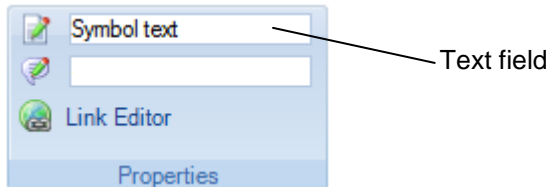

Text properties

The style property has three different settings:

Center
Rotated

The text is positioned at the line center
The text is positioned at the center of the line and will rotate according the closest line segment.

Follow

The text will be positioned at the start of the first line segment.

Over longest segment

The text will be positioned over the longest line segment.



Line text variants

The text settings can be changed in the text option found in the format shape menu.

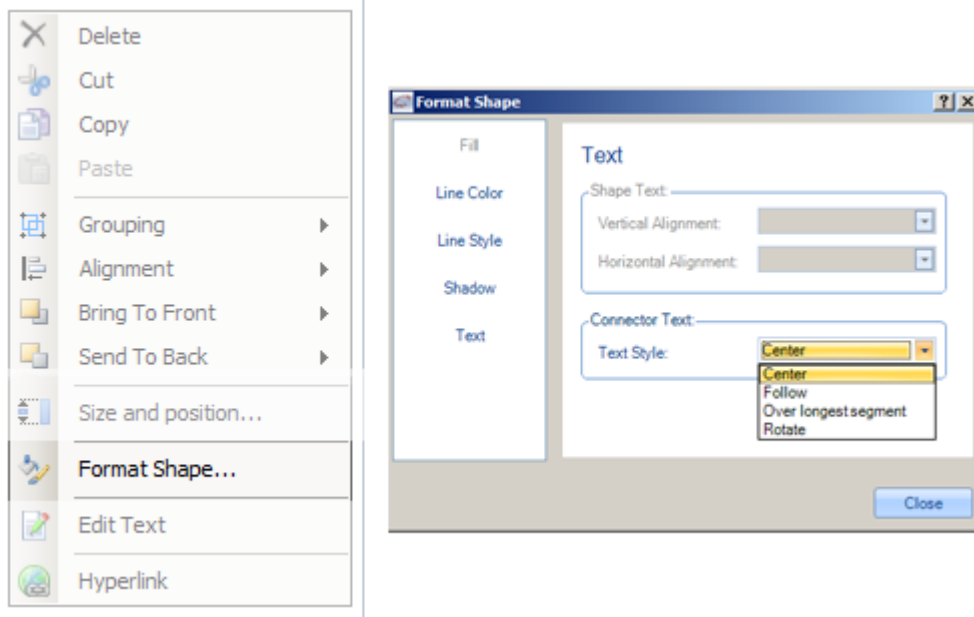

Format shape text settings

4.3.5. Connecting lines

Lines can be connected to symbols. Move a line start- or endpoint in the vicinity of the outline of a symbol. The symbols connection points will be lit. Move the line point to one of the symbol connection points. The line point will now turn red and is connected to the symbol.

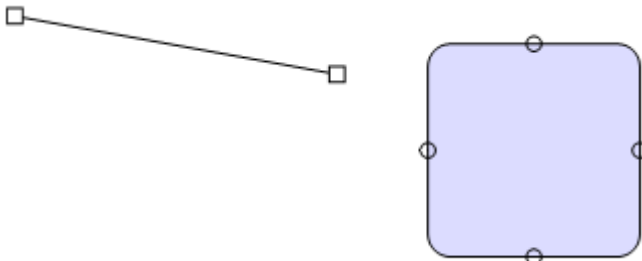

Line endpoint and symbol interconnection points

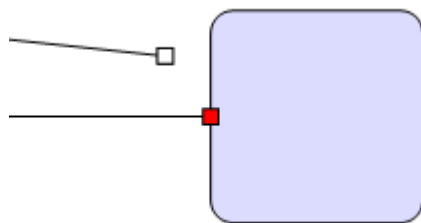

Connected line (red) versus an unconnected line (white)

Note! A connected line will remain connected to a symbol during movement.

4.3.6. Interconnecting lines

It is not possible to interconnect lines. It is however possible to position lines in a way that they appear interconnected. The easiest way to achieve this is to draw and reposition the lines using the snap to grid function.

4.3.7. Rerouting lines

The format tab command **Reroute** will optimize the selected line routing. The goal for the reroute command is to avoid obstacles if possible.

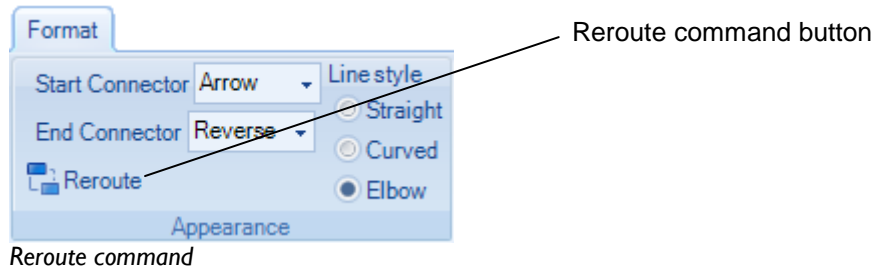

Note! The Reroute command only works on elbow lines.

4.3.8. Text objects

Text can also be added with special text objects. The text object share most properties with symbol objects and can be manipulated in the same way.

Select the text object from the symbol library. The text object has a dotted outline. The background can be set using normal object properties, but is by default set to nothing.

Add text by either changing the text settings in the format tab or by double clicking the symbol.

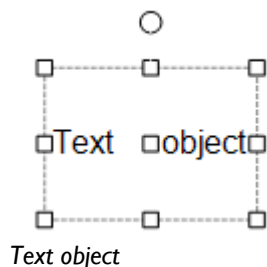

Note! If the text object is too small the text will get truncated. Use the resize handles to set the object to the correct size.

Note! The text object usage might be restricted by the administrator and is therefore not always available.

4.4. Editing a ProcessMap

The ProcessMap editor offers standard windows copy-paste functionality. Select a symbol and press and hold the right mouse button to invoke the menu.

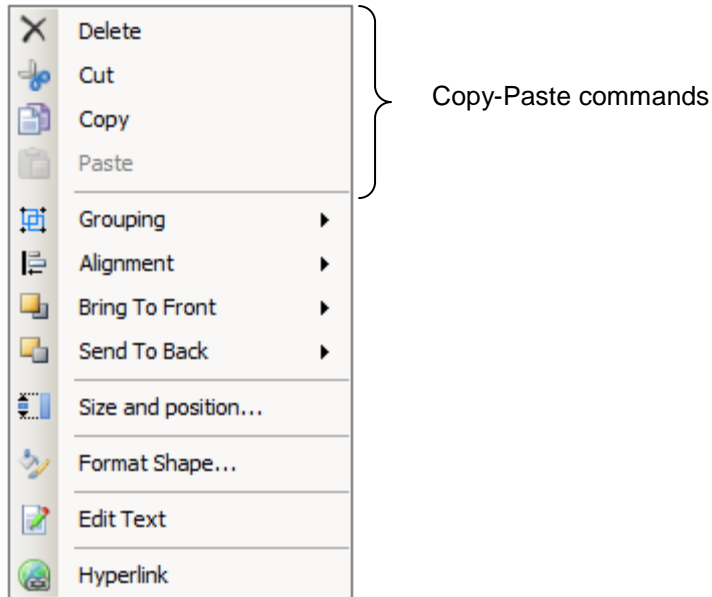

Pop up menu

Note! The copy-paste commands are also available via standard keyboard shortcuts: **Ctrl-X (cut)**, **Ctrl-C (copy)** and **Ctrl-V (paste)**.

4.5. Arranging symbols

There are no layers, but symbols can be stacked on the drawing space. How the objects are stacked determines how they are shown on the drawing space when they overlap. Select a symbol and choose **Bring to Front** or **Send to Back** on the pop-up menu to alter the stack order. The menu options **Bring Forward** and **Bring Backwards** will move the object one step in either direction.

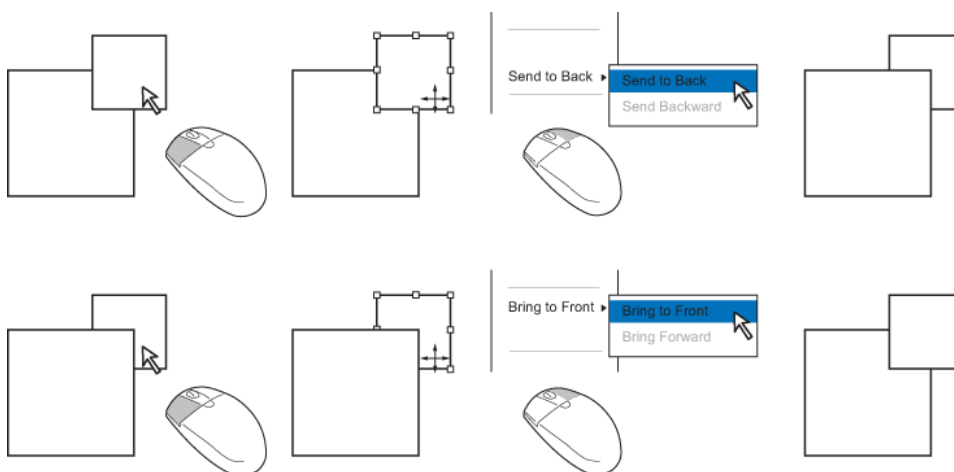

Stacking symbols

4.5.1. Grouping objects

All objects can be grouped to act like one unit. Select multiple objects as described in section 4.2.4. Press and hold the right mouse button to invoke the pop-up menu and select **Group**. All selected objects will now act as one object. Select the group and choose **Ungroup** on the pop-up menu to ungroup the objects.

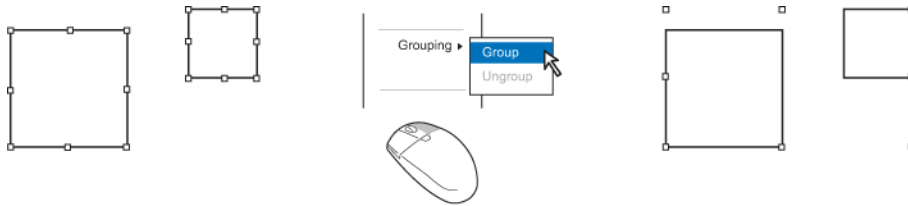

Grouping symbols

4.6. Aligning symbols

Objects can be aligned along the vertical axis by using the menu option : top, middle or bottom. To align object on the horizontal axis use the menu options: right, center or left. All objects need to be selected prior to aligning.

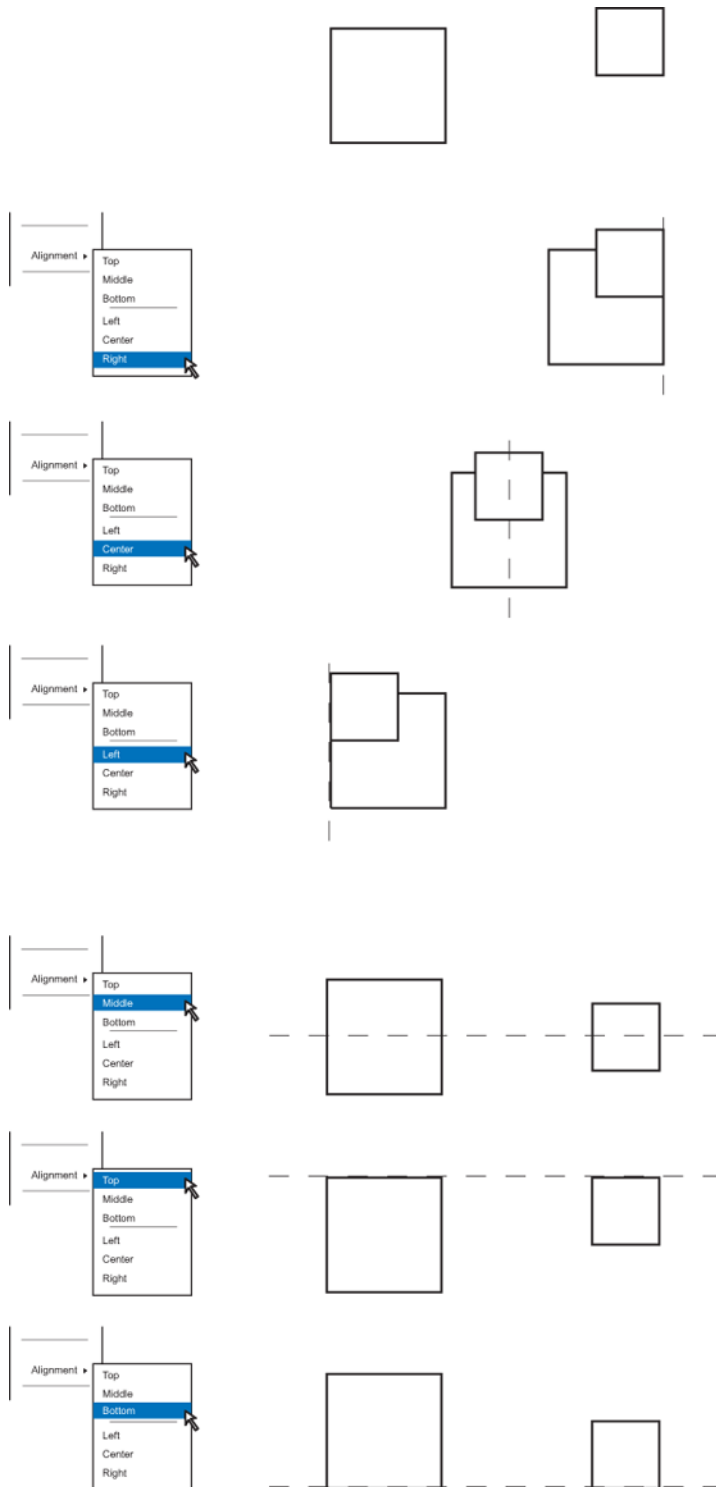

The options ***Distribute horizontally*** and ***Distribute vertically*** will distribute the objects evenly along the horizontal or vertical axis.

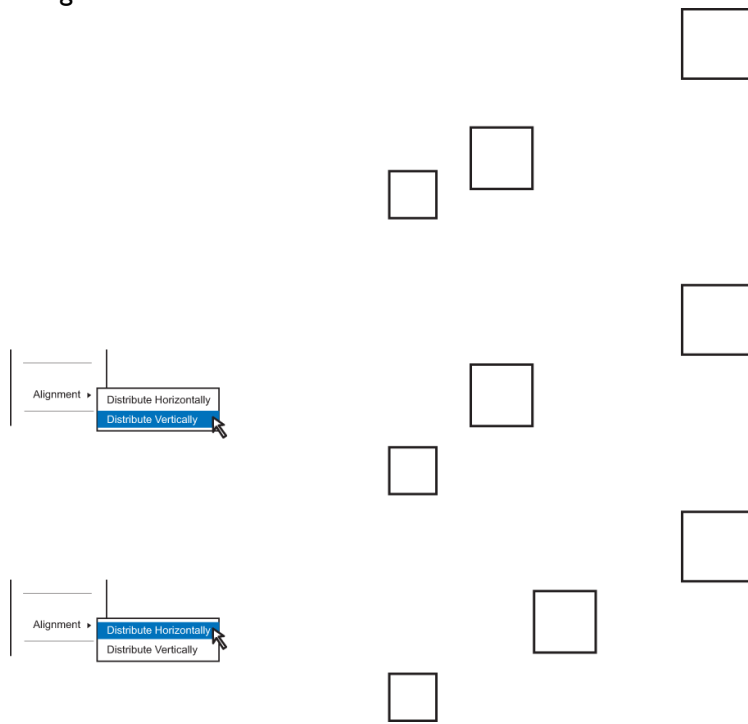

Distribute symbols

4.7. Format shape settings

The format shape properties window is invoked by selecting **Format shape** on the quick menu. The properties window holds a multitude of different settings. Since the settings are used for all symbols, lines and even backgrounds not all options are available at all times.

Note! The administrator might apply restrictions on the number of available commands.

Note! None of the settings sub pages has a cancel button. Use the *Undo* command in the quick access toolbar to undo a setting.

4.7.1. Line settings

Line settings are available if a line or symbol is selected. A line will be affected directly, whereas the setting only affects the outline of a symbol.

Line color settings

Line Color

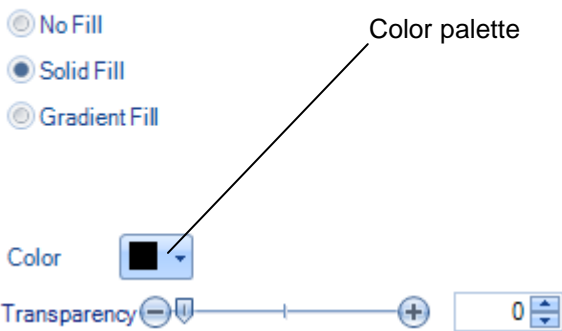

Line color settings

The option **Solid Fill** set the line color. The Color palette button displays a color palette. Transparency is set by either using the slider or inputting a value in the box. The value “0” represents no transparency and a value of “100” represents full transparency.

The setting **No Fill** should only be used when handling symbols, since the setting will make a line invisible.

Line style

Line style also handles different setting for lines or, in the case of symbols, the outline.

Line Style

Width:

Compound type:

Dash type:

Join type:

Arrow settings:

Begin type: End type:

Begin size: End size:

Line style settings

Width

This command sets the line width. Press the up or down arrows in the box or input a value to set the width. The value is set in pixels.

Compound type

This command sets the line type. Select a line type from the dropdown list.



Compound types

Dash type

This command sets different dash types. Select a dash type from the dropdown list.



Dash types

Join type

The join type option sets what type of joint that will be used between different segments in an elbow line. The possible options are: round, bevel or miter.



Join types round, bevel and miter

Arrow settings

Arrow settings set the beginning and end type of the line. This setting only applies to lines and not outlines. Select arrow type from the dropdown lists **Begin type** and **End type**. The size setting sets the size of the selected arrow.



Line with arrowheads set to 2, 4 and 6 pixels.

Note! Some of the line types in the library are already equipped with arrowheads.

4.7.2. Symbol settings

Symbol settings only affect the interior of a symbol.

Fill

Fill

- No Fill
- Solid Fill
- Gradient Fill
- Picture or texture Fill
- Slide Background Fill

Color

Transparency

Fill settings

The command **Solid Fill** set the symbol color. The Color palette button displays a color palette. Transparency is set by either using the slider or inputting a value in the box. The value “0” represents no transparency and a value of “100” represents full transparency.

Selecting **No Fill** will produce the same result as selecting **Solid Fill** and set the transparency value to “100”.

Line color

Line color settings set the outline color. See 4.7.1 for instructions how to set the line color.

Line style

Line style settings set the line type for the outline. See 4.7.1 for instructions how to set the line style.

Note! The solid fill can also be used to change the drawing space color.

4.7.3. Text

Text settings affect the way text is aligned within a symbol or how text is arranged along a line.

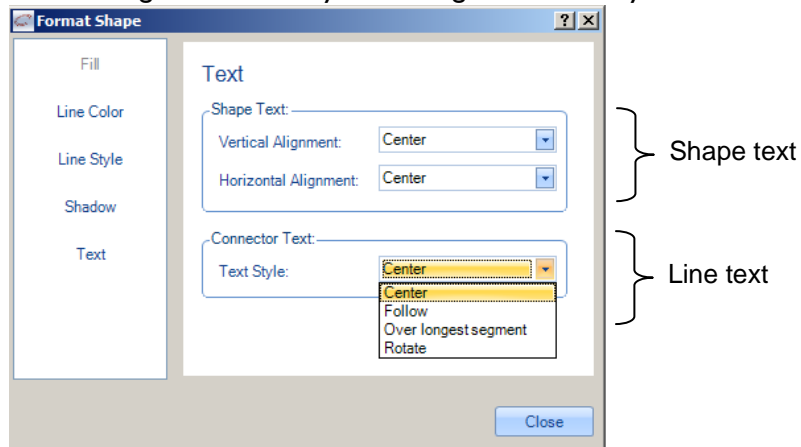

Text settings

Use the Shape text for text within a shape and Connector text for text on a line.

4.7.4. Advanced settings

Gradient fill

A gradient is an area that is filled with two or more colors. The colors fade into each other and the color pattern might also be in an angle.

Fill

- No Fill
- Solid Fill
- Gradient Fill
- Picture or texture Fill
- Slide Background Fill

Preset Color: 

Type:

Direction: 

Angle:

Position 

Color 

Transparency 

Gradient fill

Preset color

This setting uses completely predefined gradients. If this setting is used the remaining gradient settings are not used.

Type

The gradient can be either be linear or a path gradient. The linear gradient goes by default from left to right whereas the path gradient mimics the shape and goes from the outer part of the symbol towards the center.



Linear and path gradient

Direction

The Direction setting set the gradient angle. Either use the angle presets in the direction dropdown list or enter a value in the angle input box.



Linear gradient at 0 and 45 degrees

Gradient color setup

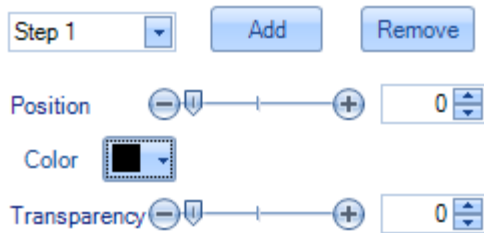

The gradient can include a number of different colors. Each color represents a step. Add steps by pressing the Add button. Remove steps by selecting the step in the dropdown menu followed by pressing the Remove button.

Each step has a position setting. Alter the setting by using the slider or by entering a value. The value “0” represents the left side of the symbol whereas “100” represents the right side of the symbol. Each step also has settings for color and transparency. Use the slider and dropdown menu to set these values.

Note! The position settings are not valid for the first and last steps. These steps are always positioned at “0” and “100”.

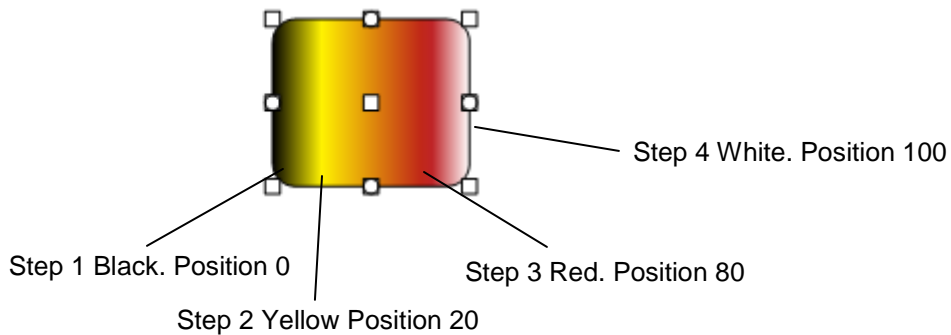

A shape with a gradient with 4 steps

Note! A gradient fill can also be used for the drawing space.

Picture Fill

The picture fill uses an image to fill a symbol instead of a solid color.

Fill

- No Fill
- Solid Fill
- Gradient Fill
- Picture or texture Fill
- Slide Background Fill

File...

Alignment: Center

Picture fill

Load the image by pressing the File button. Choose alignment by selection one of the options in the drop down menu.

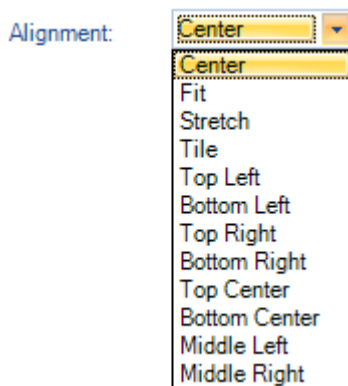

Alignment settings

The option **Fit** will place the picture in the symbol and keep the picture's aspect ratio. The option **Stretch** will fill the symbol with the picture, and if the symbol does not have the same aspect ratio as the picture, then the picture might appear stretched either horizontally or vertically. The remaining options will display a portion of the picture, i.e. the option **Top Left** will only display the top left of the image as long as the shape is smaller than the picture. The option **Tile** tiles the picture horizontally and vertically. This requires the picture to be smaller than the symbol.



Picture settings fit, stretch and middle right

Shadow

The shadow setting will add a shadow to the selected object.

Shadow

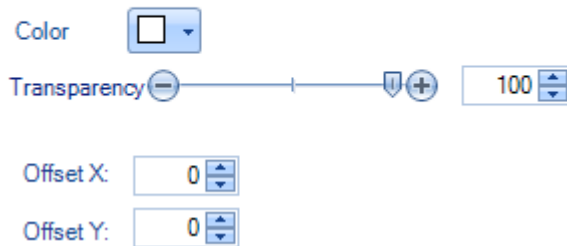

Shadow settings

Use the **Color** dropdown list to set the shadow color and use the slider to set the transparency. The value “0” represents no transparency and a value of “100” represents full transparency.

Use the settings **Offset X** and **Offset Y** to move the shadow. A slightly transparent and offset shadow will give the impression that the line is floating above the background.

Note! The possibility to add a shadow to an object might be restricted by the administrator.

4.8. Custom symbols

ProcessMap is delivered with a handful of standard symbols. Since symbols used for process map creation differ vastly in appearance custom symbols can be added to accommodate special needs. Please refer to the “ProcessMap: Installation & administration manual” for more information on how to add custom symbols.

4.9. Adding content

To further enhance the process it is possible to add content to symbols. Content can be in the form of a web-link, either external or within the EPiServer, an e-mail address or a file. A single symbol can hold several different types of content.

Proceed in the following way to create content:

1. Select a symbol.
2. Press the right mouse button to invoke the menu.
3. Select **Hyperlink** from the menu, which will start the link editor. Select **+** to add a link, **✎** to edit an existing link or **✖** to delete a link.
4. Set specific site specific properties if applicable.

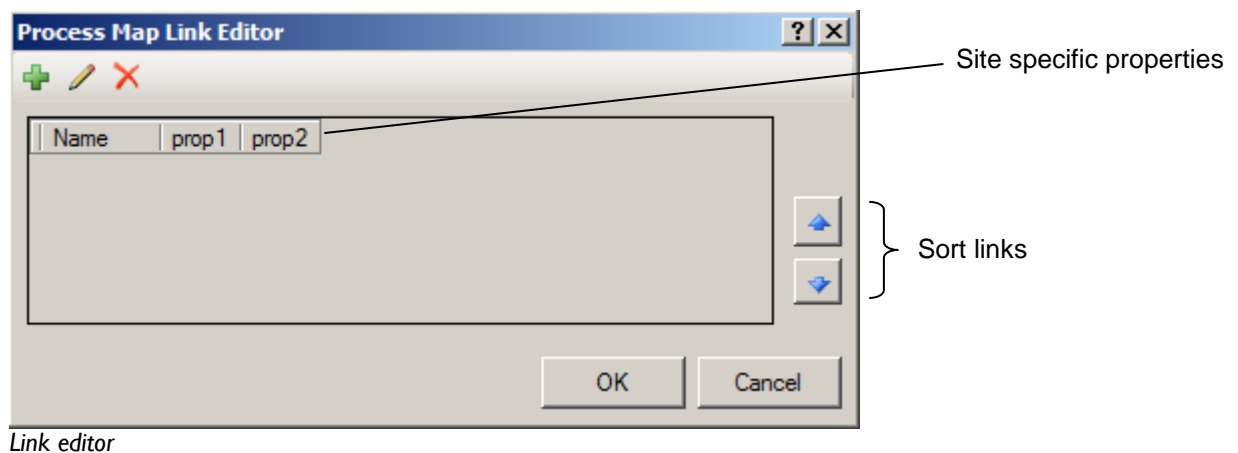

Note! Site specific properties can for example be how a symbol with a link is displayed, i.e. a special background color. Contact the site administrator for information regarding link properties.

Adding or editing a link will start the Link tool. The upper static window pane holds information about the link's name and the target frame. Set the link name to a short informative name. This name will be displayed in a menu, on the ProcessMap, when the user clicks on the symbol.

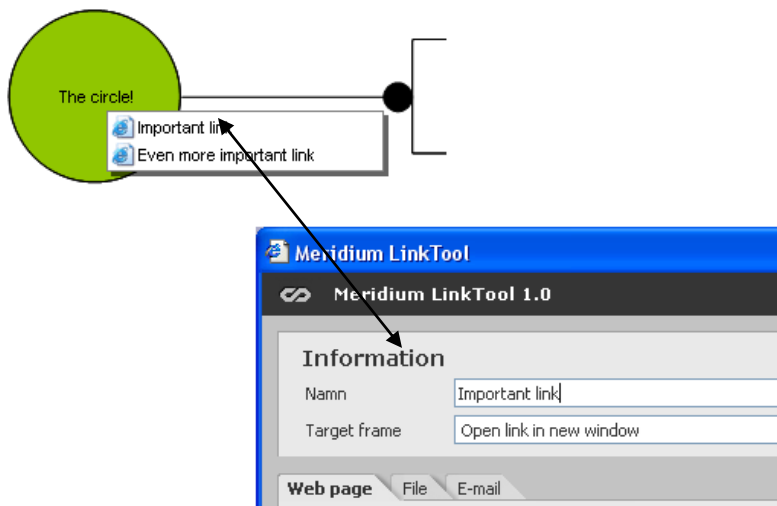

Link name

The target frame field will set if the link will be displayed in a new window or in the same window as the ProcessMap itself.

There are four tabs in the lower window pane, each for different type of links.

Note! It is only possible to select one link type for each link. Consecutive selections will override the previous selection.

4.9.1. Web page link

Web page tab

Choose one of the two selections using the radio buttons:

Page on another web-site

Select a valid http-link.

Bookmark on this page

Select a predefined bookmark that has been previously created on this ProcessMap page.

Note! The bookmark must be present in one of the EPiServer text fields on the current page or in the template used to create it.

4.9.2. File link



The screenshot shows a configuration window with four tabs: 'Web page', 'File', 'E-mail', and 'EPIserver'. The 'File' tab is selected and highlighted. Below the tabs, the word 'Target' is displayed in bold. Underneath, there is a radio button labeled 'Document on the network' which is selected. To the right of this radio button is a text input field containing the text 'file:///'. The background of the window is a light gray color.

File tab

Document on the network

Select a document that is located on the local network. Use the syntax: [file:///C:/file.ext.](#)

Warning! Security setting for local and remote users might prevent users to access a specific file.

4.9.3. E-mail address



The screenshot shows a configuration window with four tabs: 'Web page', 'File', 'E-mail', and 'EPIserver'. The 'E-mail' tab is selected and highlighted. Below the tabs, the word 'Target' is displayed in bold. Underneath, there is a radio button labeled 'E-mail address' which is selected. To the right of this radio button is an empty text input field. The background of the window is a light gray color.

E-mail tab

E-mail address

Enter a valid e-mail address. The link will invoke the users default e-mail software.

4.9.4. EPiServer link

The screenshot shows a dialog box titled 'EPiServer' with tabs for 'Web page', 'File', 'E-mail', and 'EPiServer'. The 'EPiServer' tab is selected. Below the tabs is a section titled 'Target'. There are three radio button options: 'Page on this Web site' (which is selected), 'Language', and 'Document on this Web site'. The 'Page on this Web site' option has a text input field and a button with three dots. The 'Language' option has a dropdown menu showing 'English'. The 'Document on this Web site' option has a text input field and a button with three dots.

Web server tab

Page on this website

Select a page from the web-page browser. All pages in the browser are located on the local EPiServer. Press to open the browser.

Language

The language field will limit the available selection in the **Page on this Web site** to pages available in the selected language.

Document on this web site

Select a document that is located on this web-site. Contact your administration for information where content is stored on your server. Start the file browser by pressing the button

Acknowledge the link setting by pressing the **Ok** button. The link tool will close and the link editor will become visible again. Either add more content by selecting the button or return to the graphical editor by pressing **Ok**.

Once the symbols have been equipped with content the ProcessMap creation is complete. The page can now be published using standard EPiServer methodology.